

Performance Curve

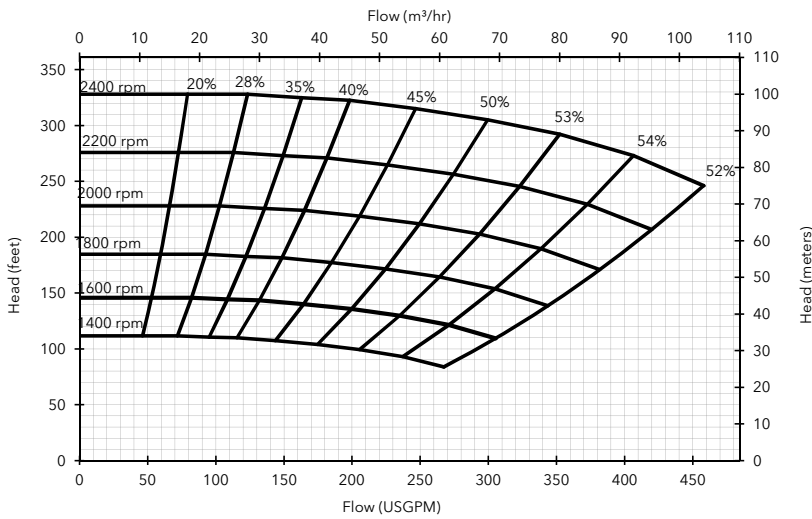

Engine option 1

John Deere 4045TF290 (IT4 Flex), 74 HP @ 2400 rpm

Impeller diameter 12.8"

Pump speed 2400 rpm

Suction Lift Table

Total Suction Head (feet)	Total Delivery Head (feet)				
	176	227	257	287	297
	Output (USGPM)				
10	491	436	382	300	245
15	480	425	354	229	-
20	436	392	327	245	-
25	316	300	273	164	-

Fuel capacity: 60 US Gal

Max Fuel consumption @ 2400 rpm: 4.5 US Gal/hr

Max Fuel consumption @ 2000 rpm: 4.1 US Gal/hr

Weight (Dry): 2,960 lbs

Weight (Wet): 3,380 lbs

Dimensions: (L) 119" x (W) 66" x (H) 77"

Performance data provided in tables is based on water tests at sea level and 20°C ambient. All information is approximate and for general guidance only. Please contact the factory or office for further details.

Materials

Pump casing & suction cover	Cast iron BS EN 1561 - 1997
Wearplates	Cast iron BS EN 1561 - 1997
Pump Shaft	Carbon steel BS 970 - 1991 817M40T
Impeller	Cast Steel BS3100 A5 Hardness to 200 HB Brinell
Non-return valve body	Cast iron BS EN 1561 - 1997
Mechanical seal	Silicon carbide face; Viton elastomers; Stainless steel body

Engine option 2

Caterpillar C4.4M-T (Export Only), 78 HP @ 2200 rpm

Impeller diameter 12.8"

Pump speed 2200 rpm

Suction Lift Table

Total Suction Head (feet)	Total Delivery Head (feet)				
	147	189	214	239	248
	Output (USGPM)				
10	450	400	350	275	225
15	440	390	325	210	-
20	400	360	300	225	-
25	290	275	250	150	-

Fuel capacity: 60 US Gal

Max Fuel consumption @ 2200 rpm: 4.6 US Gal/hr

Max Fuel consumption @ 1800 rpm: 4.2 US Gal/hr

Weight (Dry): 2,950 lbs

Weight (Wet): 3,370 lbs

Dimensions: (L) 119" x (W) 66" x (H) 77"

Performance data provided in tables is based on water tests at sea level and 20°C ambient. All information is approximate and for general guidance only. Please contact the factory or office for further details.

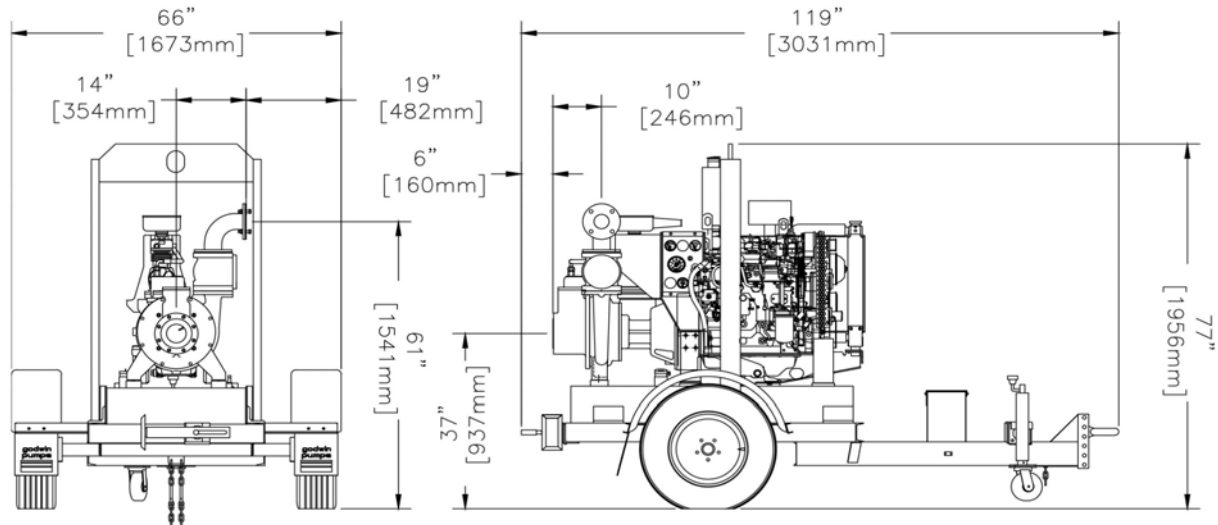

84 Floodgate Road
Bridgeport, NJ 08014 USA
(856) 467-3636 . Fax (856) 467-4841
Email: sales@godwinpumps.com

Reference number : 95-1108-3000
Date of issue : February 26, 2014
Issue : 3

www.godwinpumps.com