

Performance Curve

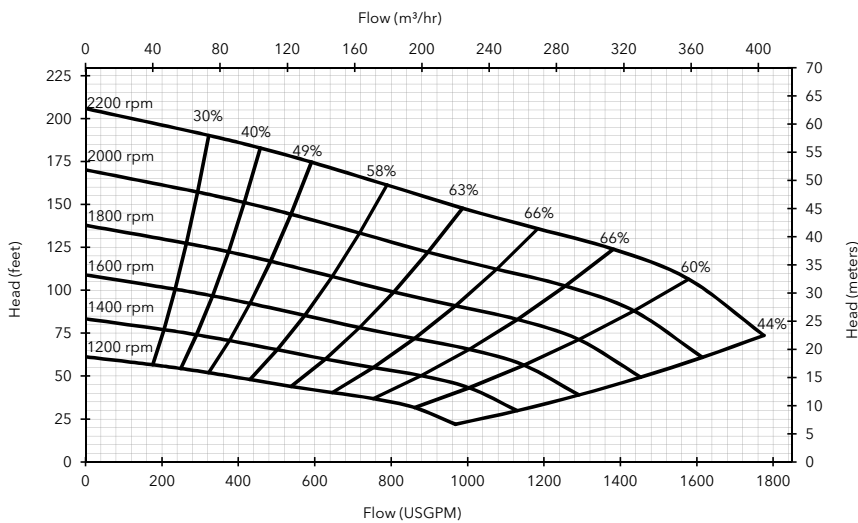

Engine option 1

John Deere, 4045TF290 (IT4 Flex), 75 HP @ 2200 rpm

Impeller diameter 11.3"

Pump speed 2200 rpm

Suction Lift Table

Total Suction Head (feet)	Total Delivery Head (feet)				
	64	115	151	167	187
	Output (USGPM)				
10	1574	1211	581	363	48
15	1308	1114	533	242	-
20	1090	969	339	-	-
25	848	678	242	-	-

Fuel capacity: 60 US Gal

Max Fuel consumption @ 2200 rpm: 4.4 US Gal/hr

Max Fuel consumption @ 1800 rpm: 3.8 US Gal/hr

Weight (Dry): 3,080 lbs

Weight (Wet): 3,500 lbs

Dimensions: (L) 119" x (W) 66" x (H) 77"

Performance data provided in tables is based on water tests at sea level and 20°C ambient. All information is approximate and for general guidance only. Please contact the factory or office for further details.

Materials

Pump casing & suction cover	Cast iron BS1561:1997
Wearplates	Front - Hard Iron EN12513:2000 Rear - Cast Iron BS1561:1997 0
Pump Shaft	Carbon steel BS970:1991 817M40T
Impeller	Hard Iron EN12513:2000
Non-return Valve body	Cast iron BS1561:1997
Mechanical Seal	Silicon carbide face; Viton elastomers; Stainless steel body

Engine option 2

John Deere, 4045TFC03 (FT4), 74 HP @ 2200 rpm

Impeller diameter 11.3"

Pump speed 2200 rpm

Suction Lift Table

Total Suction Head (feet)	Total Delivery Head (feet)				
	66	117	153	169	189
	Output (USGPM)				
10	1574	1211	581	363	48
15	1308	1114	533	242	-
20	1090	969	339	-	-
25	848	678	242	-	-

Fuel capacity: 60 US Gal

Max Fuel consumption @ 2200 rpm: 4.6 US Gal/hr

Max Fuel consumption @ 2000 rpm: 4.4 US Gal/hr

Weight (Dry): 3,240 lbs

Weight (Wet): 3,660 lbs

Dimensions: (L) 119" x (W) 66" x (H) 91"

Performance data provided in tables is based on water tests at sea level and 20°C ambient. All information is approximate and for general guidance only. Please contact the factory or office for further details.

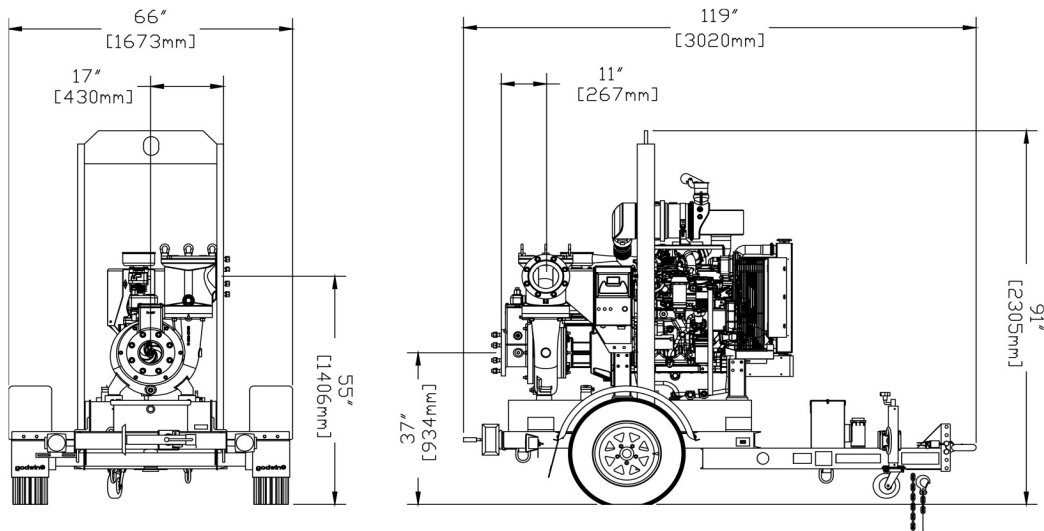

84 Floodgate Road
Bridgeport, NJ 08014 USA
(856) 467-3636 . Fax (856) 467-4841
Email: sales@godwinpumps.com

Reference number : 95-1805-3000
Date of issue : September 17, 2014
Issue : 9

www.godwinpumps.com